

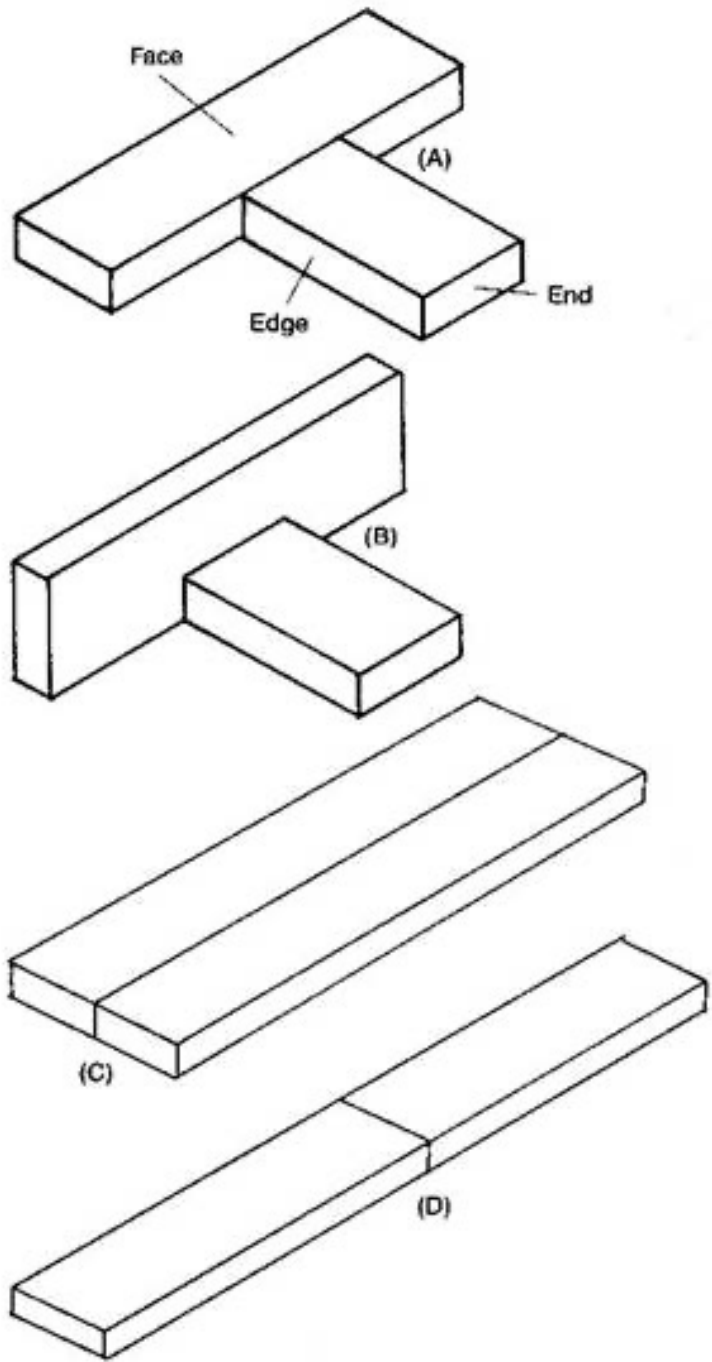

การสร้างฉากเวที

Butt Joint



Lap Joint

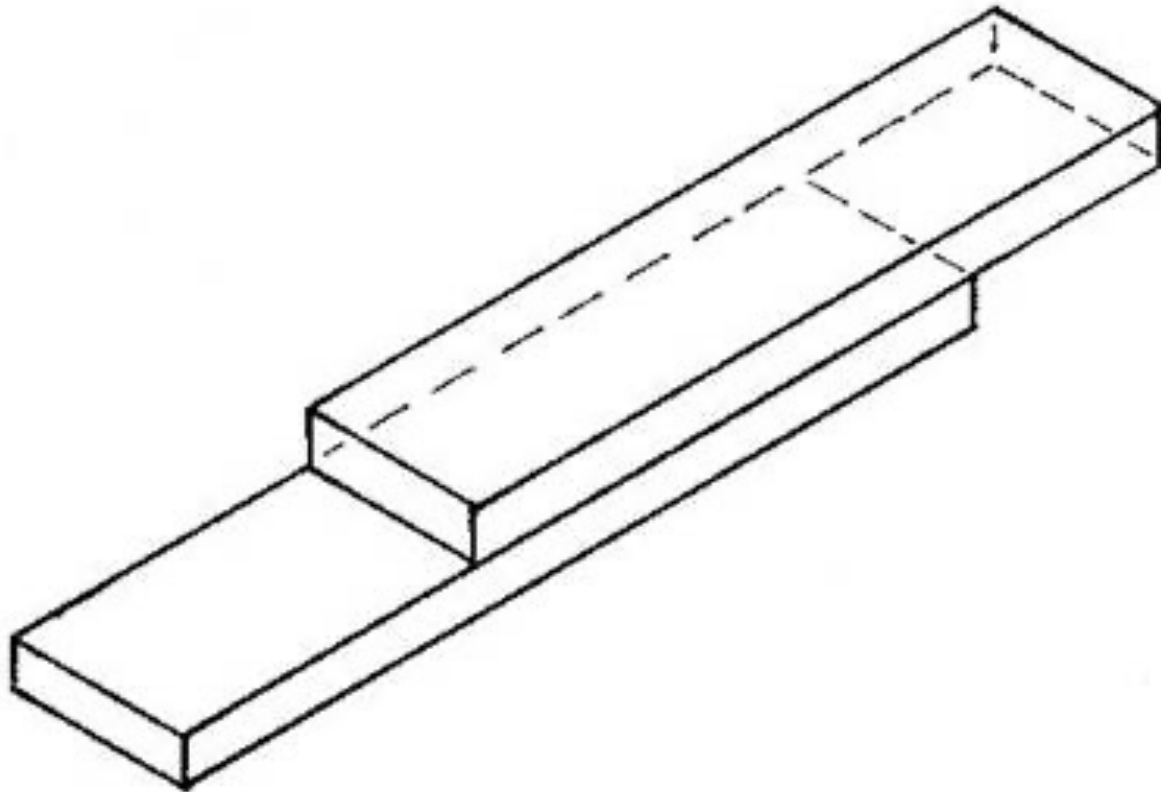

Battened Butt Joint

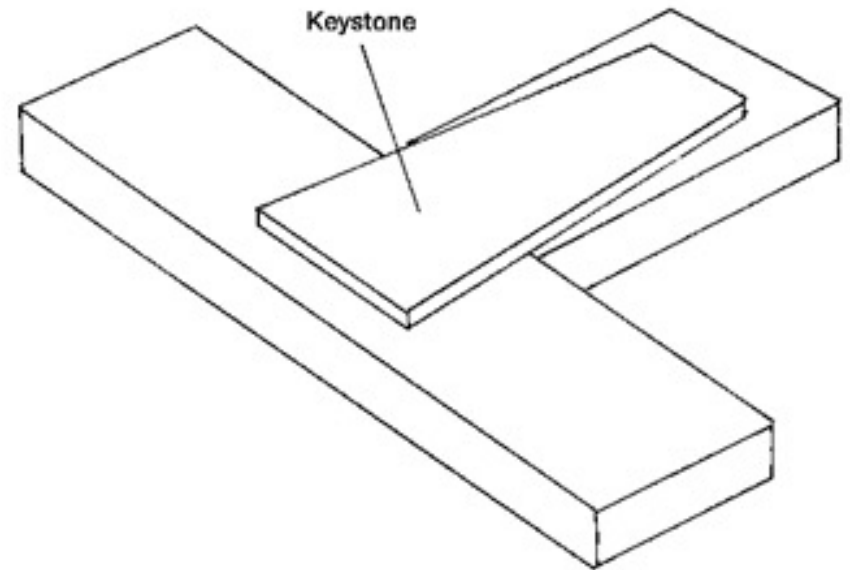
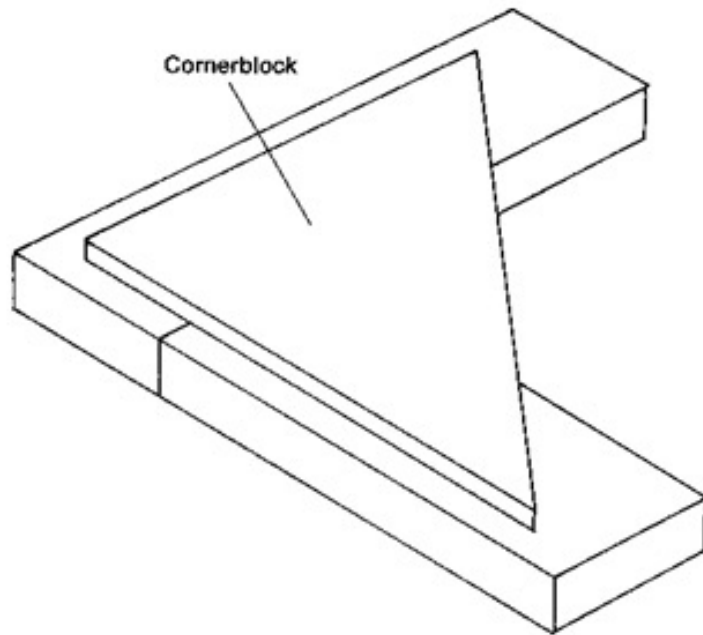

Miter Joint

“Irregular flat”

A flat that has
nonsquare
corners!

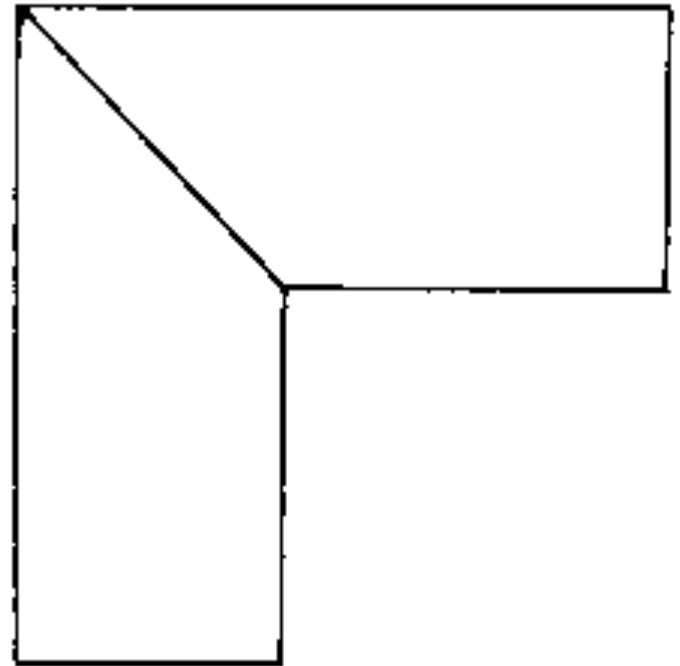

Notched Joint

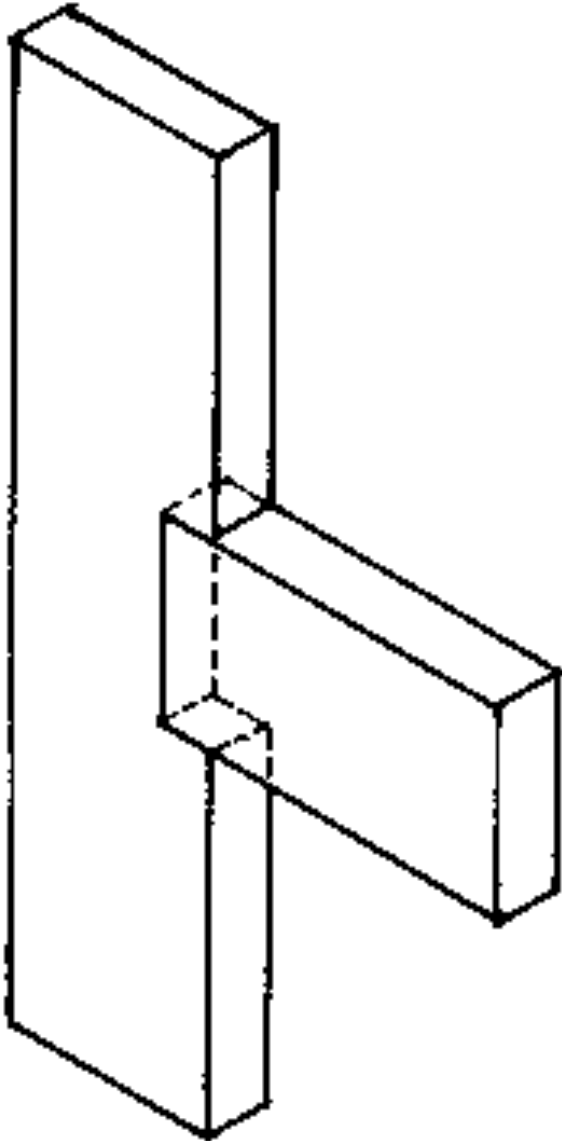

Scarf Joint

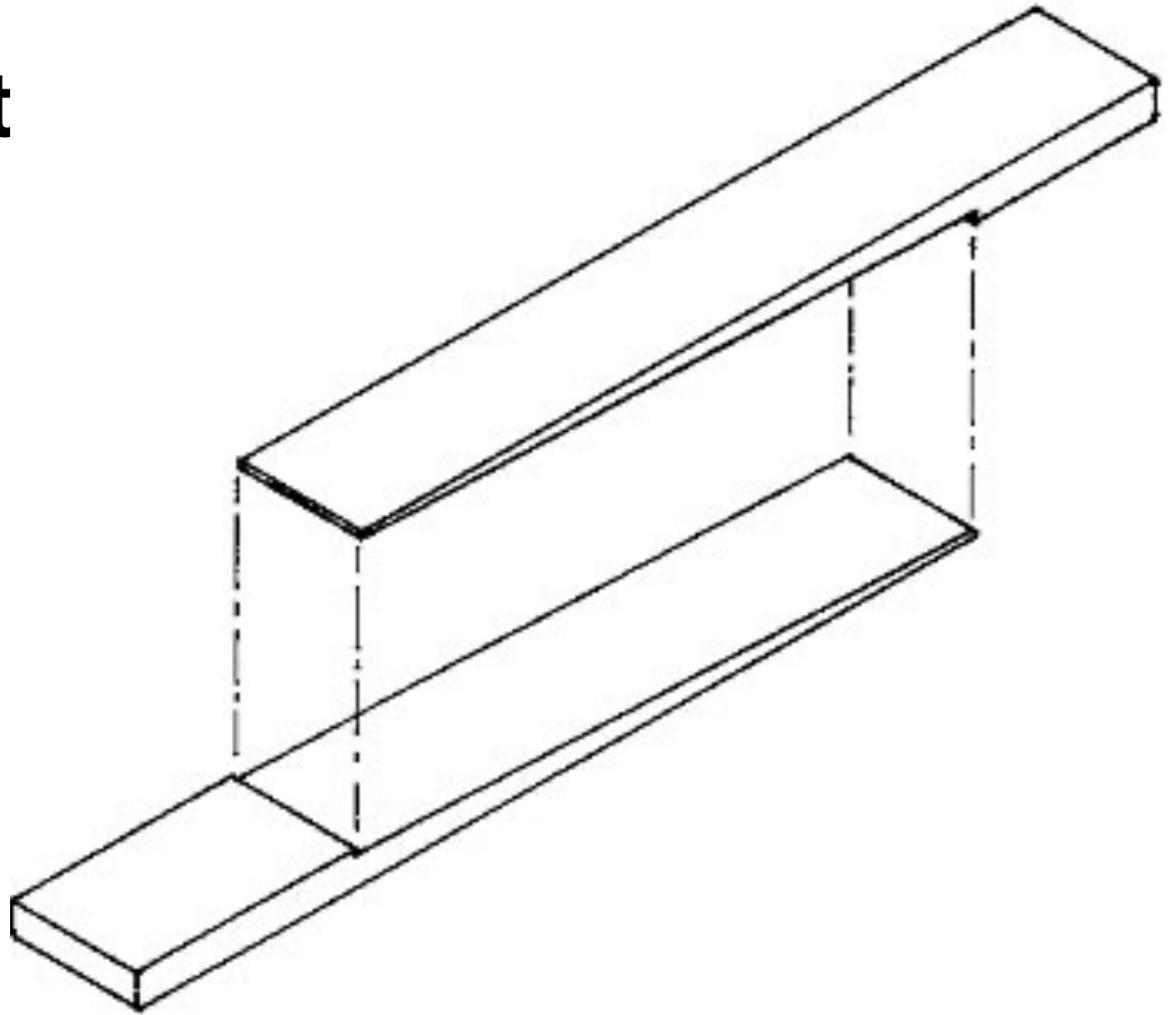

Doweled Joint

open doweled joint

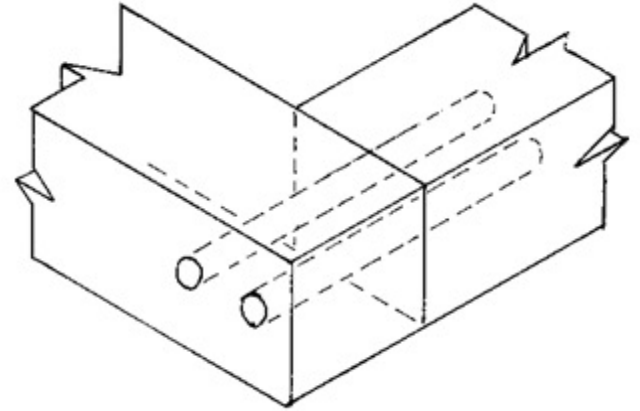

closed doweled joint

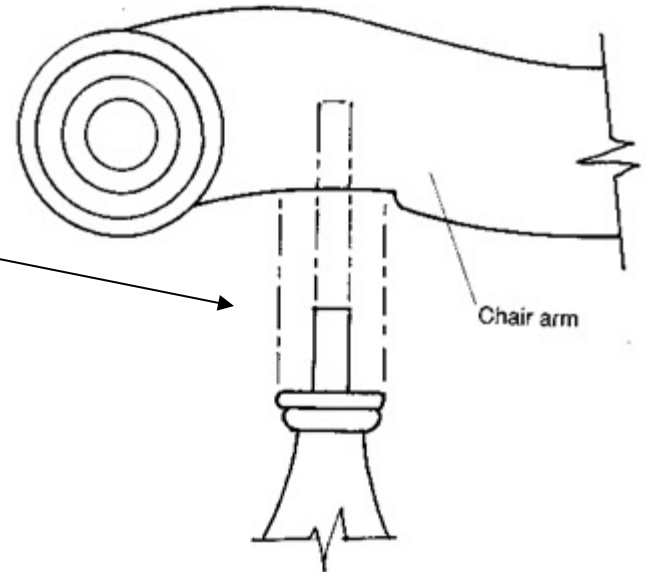

Two-Dimensional Scenery

Two-dimensional scenery can be divided into two basic subgroups

Hard scenery—Flats

Soft scenery—Unframed units such as drops and draperies

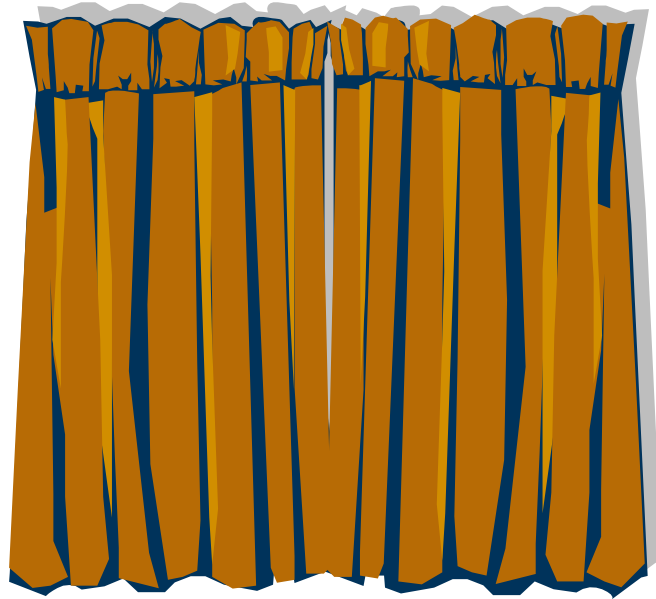

Flats

Rail—top or bottom framing member

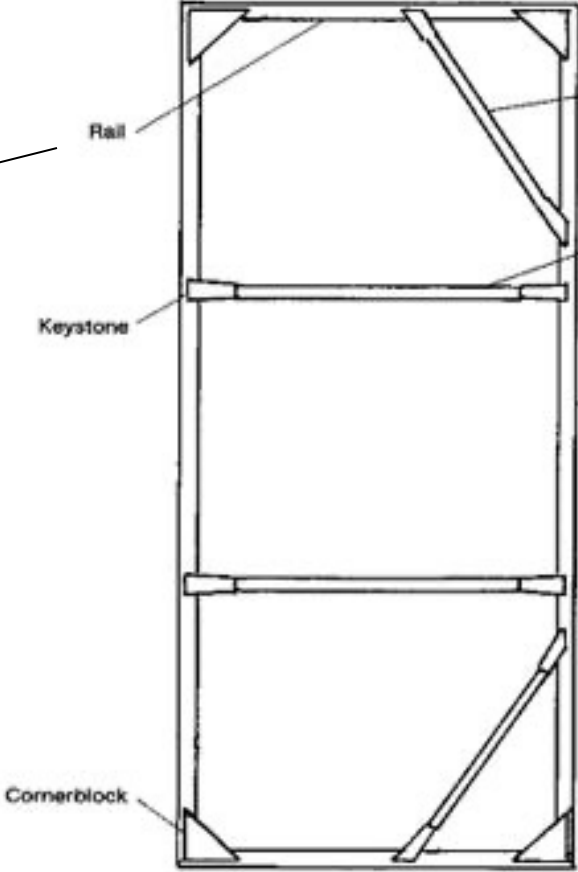

Diagonal brace

Toggle Bar—an interior horizontal framing member

Toggle bar

Keystone

Stile

Stile—a vertical side member

Cornerblock

Hard Scenery—Flats

Flats are lightweight frames made of wood or steel tubing

They are normally covered with muslin but can be covered with plywood, Upson board, paper, Masonite, velour, or other fabrics

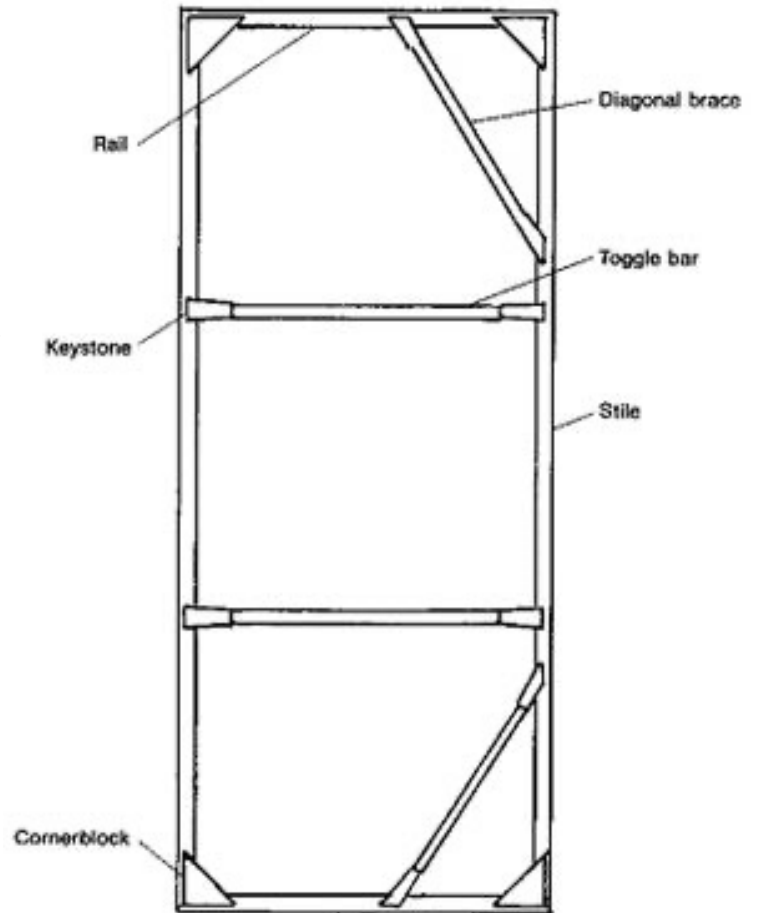

- **Rails** -These are the top and bottom pieces of lumber that determine the width of the flat
- **Stiles** - these are the side pieces of lumber that determine the height of the flat.
- **Toggles** - these are the pieces of lumber that give support to soft cover flats. They should be placed every 3-4 feet.
- Corner braces -these help keep a soft cover flat square.
- Fasteners - corner blocks, for stile and rail joints
- Half-straps, for fastening the corner braces to the rail and stile
- Straps-for fastening the toggles to the stiles.

Stage Platforming

Platforms are used to create levels

There are several types of platforms

Rigid Wooden Platform

Rigid Steel-Tubing Platform

Stressed-Skin Platform

Honeycomb-Paper Lamination

Parallels

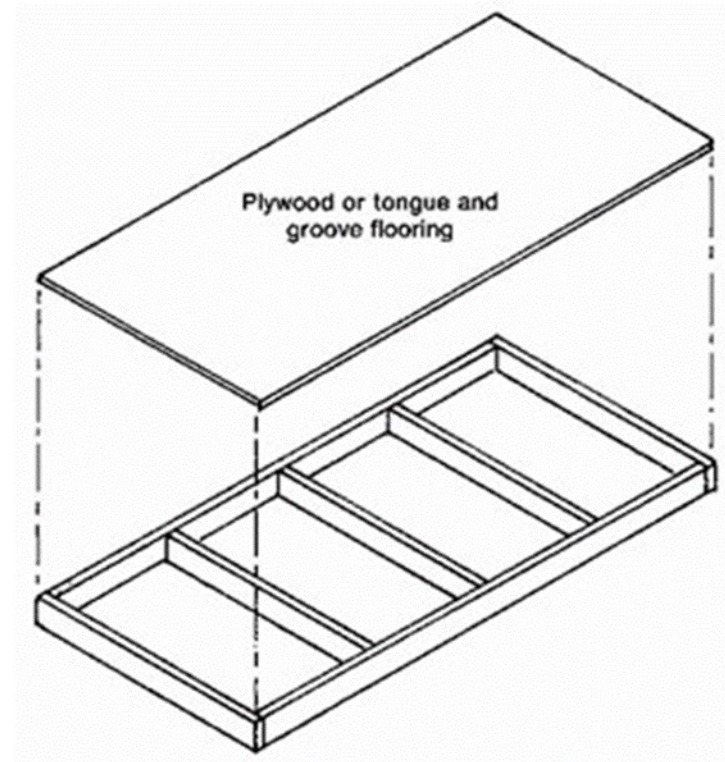

Stairs

$\frac{3}{4}$ " Plywood
(grain running
as illustrated)

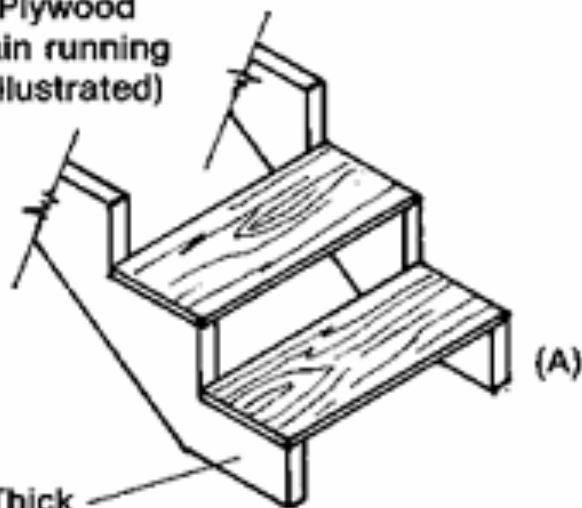

2" Thick
carriages

(A)

Riser (rests
in back of tread)

Tread (lip
extends even
with or past riser)

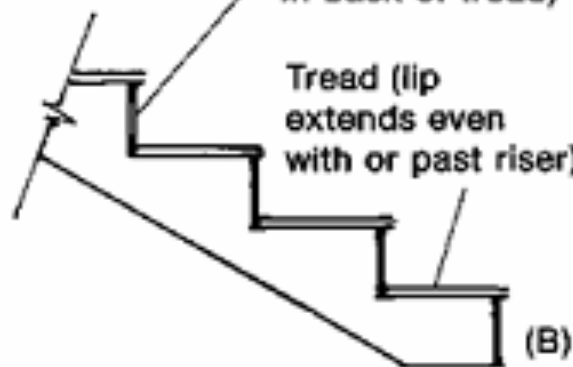

(B)

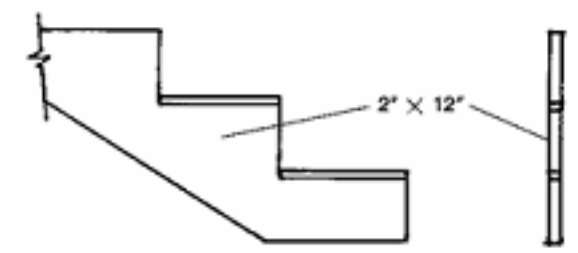
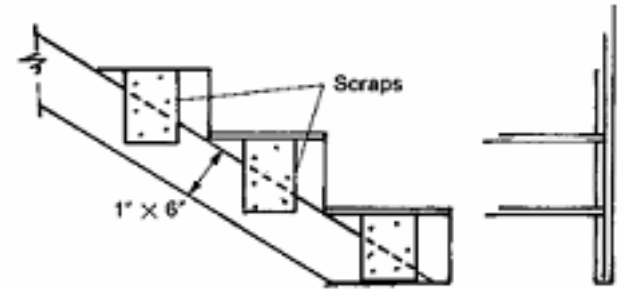
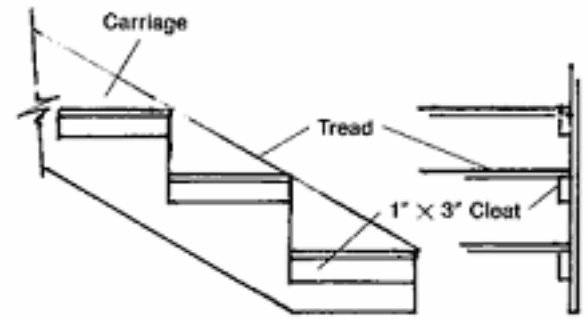

Staircase Railings

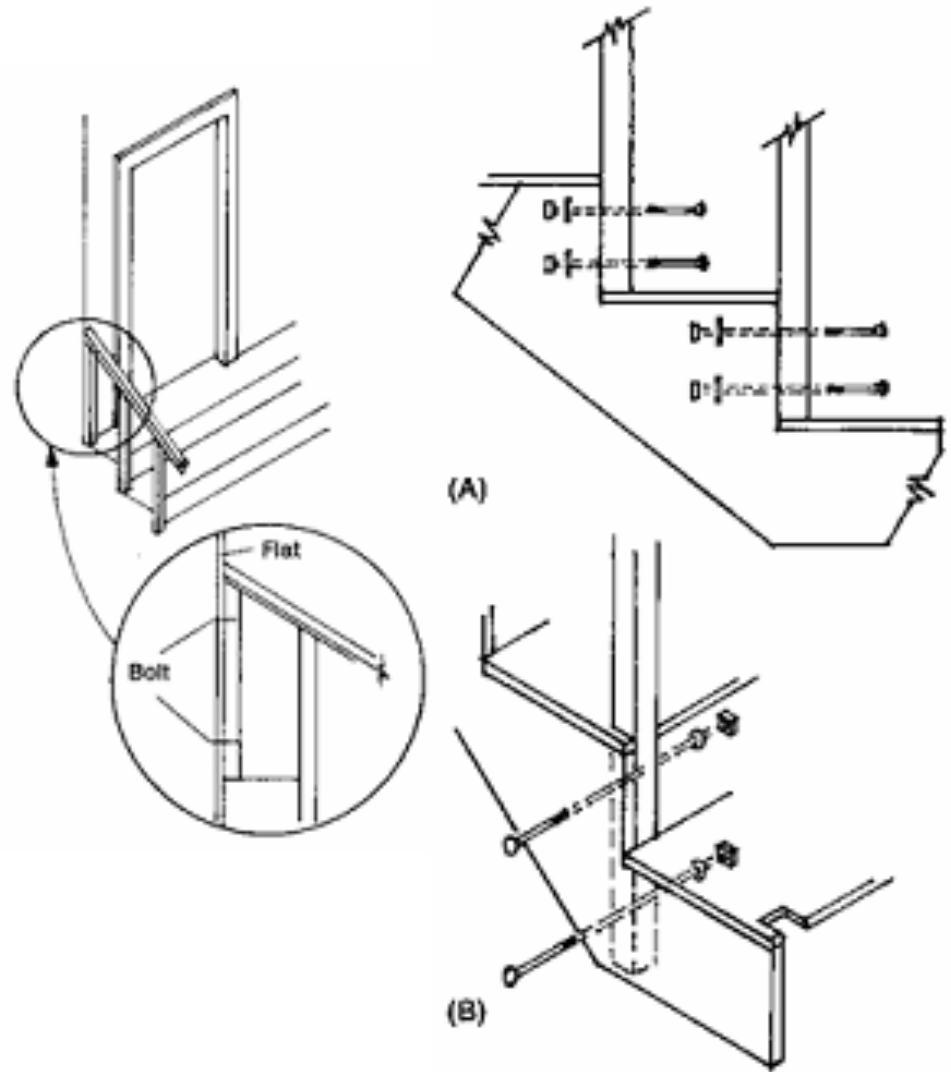

Flats

Soft Flats—any flat covered with fabric

Studio Flats—also called Hollywood-style flats, are framed flats that are covered with hard materials, such as plywood. These flats place the framing wood on edge rather than flat for strength

Metal-Framed Flats—uses square metal tubing rather than lumber to frame the flat

Flats

Door and Window Flats

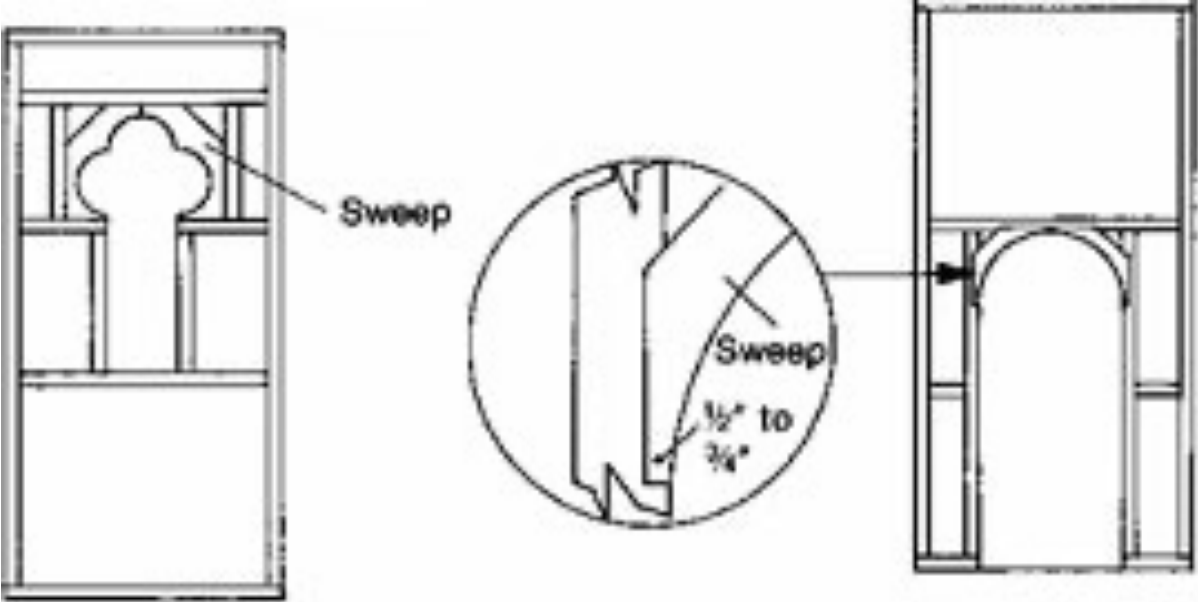

Flats: Door and Window Flats

There are two types of stage windows and doors

Dependent—unit is fixed to the flat

Independent—unit is largely self-contained and can easily be attached to or removed from the flat

Flats: Joining Flats

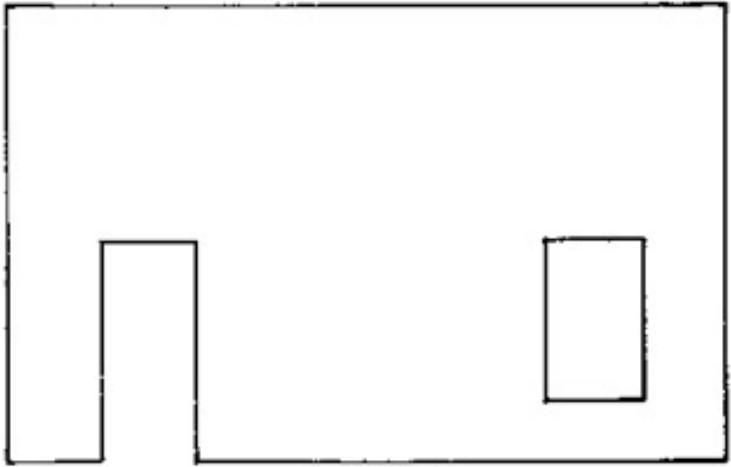

Front elevation

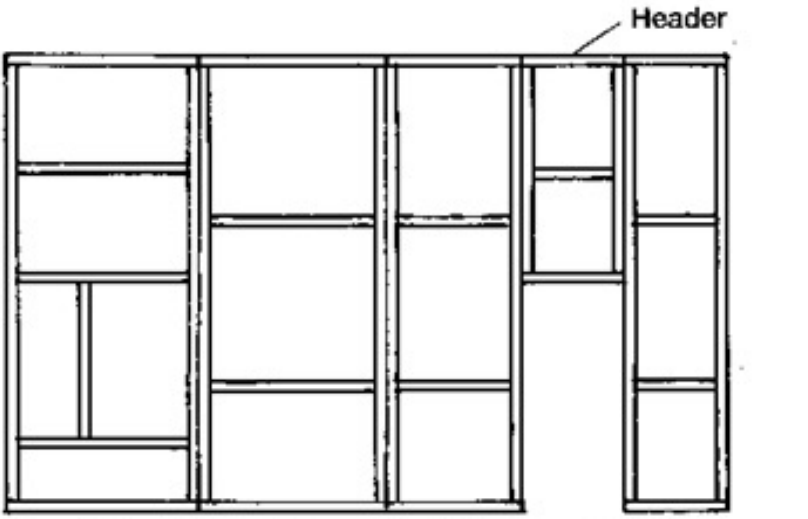

Header

Rear elevation

Flats: Rigid Joining

If the multiflat wall does not need to fold, this type of joining is used

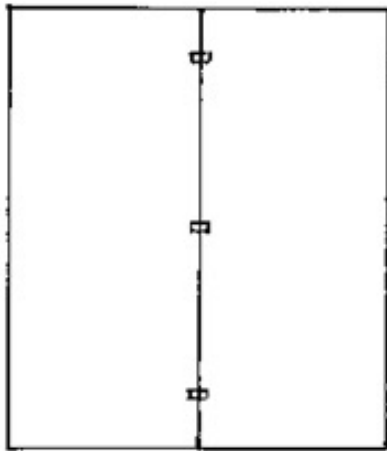

Tight pin hinges
on face of flats
no more than 5'-0"
between hinges

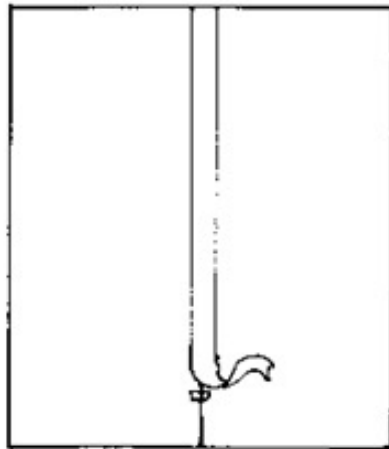

Cover joint
with dutchman

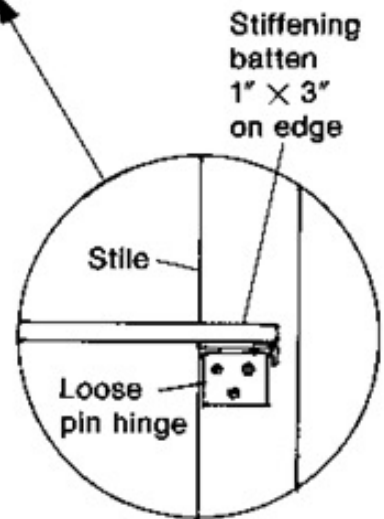
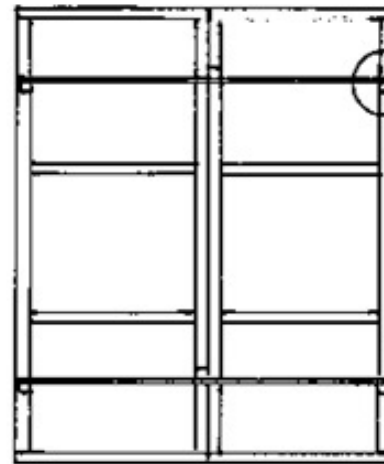

Flats: Flexible Joining

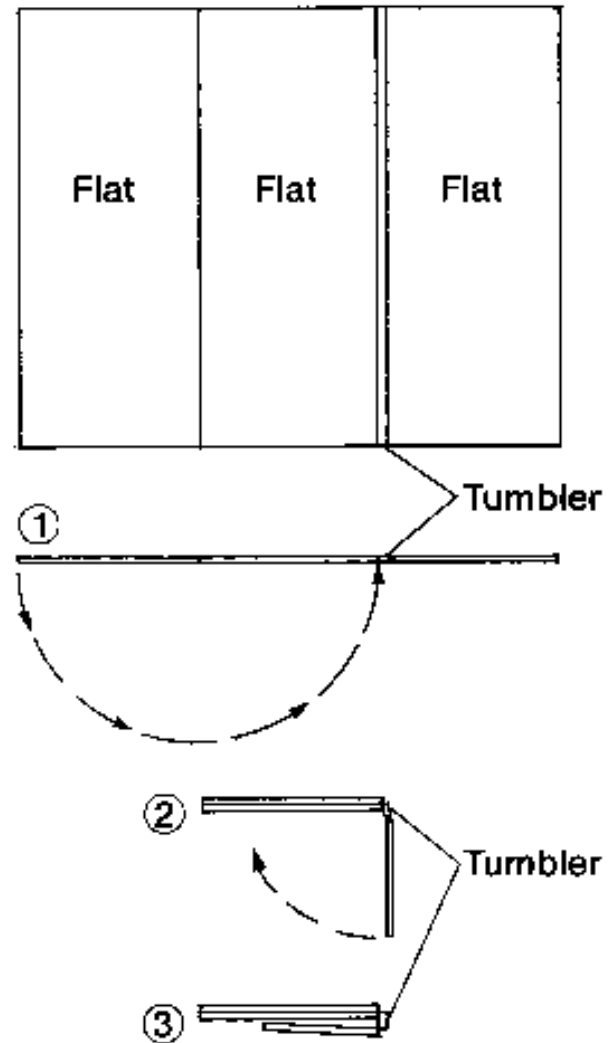

Flats: Ceilings

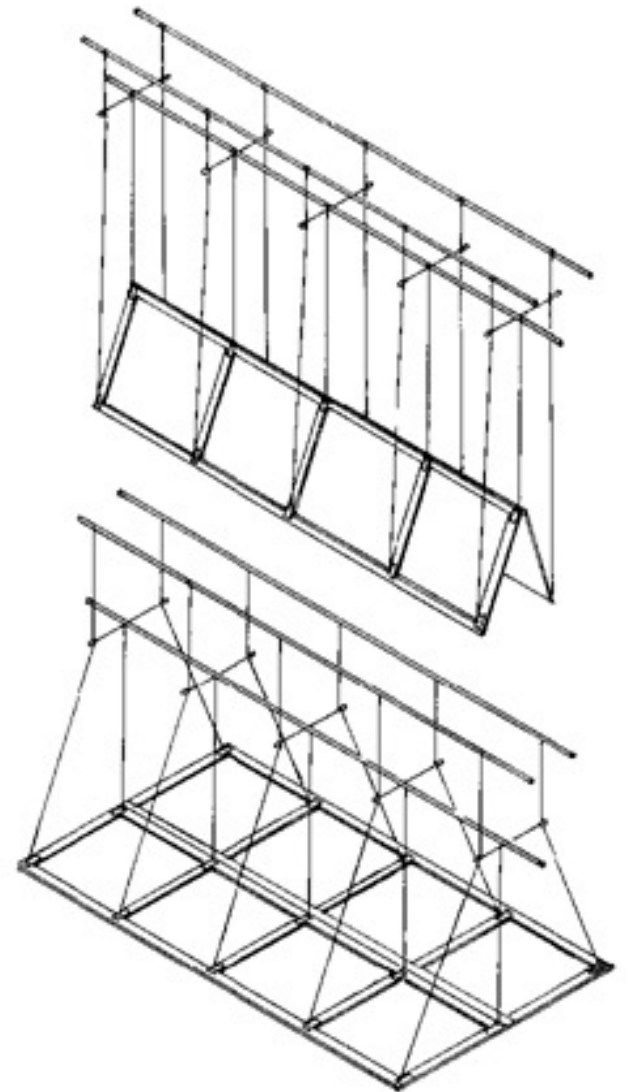
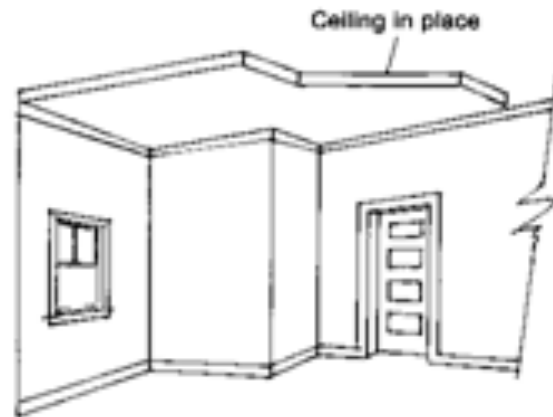
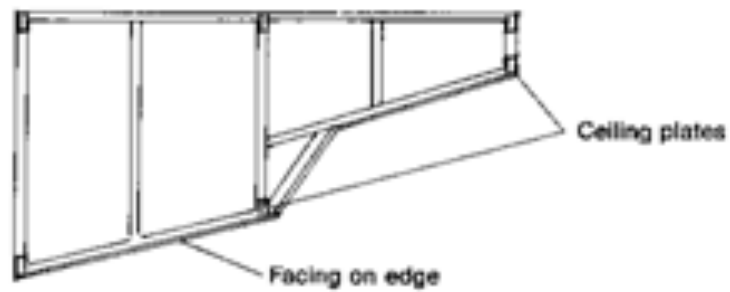

Soft Scenery: Drops

Drops are large, flat curtains that have no fullness

Tie-Supported Drops

Batten-Clamp Drops

Opaque Drops

Translucent Drops

Scrim Drops

Cutout Drops

Soft Scenery: Tie-Supported Drops

The easiest way of hanging a drop is to tie it to the batten

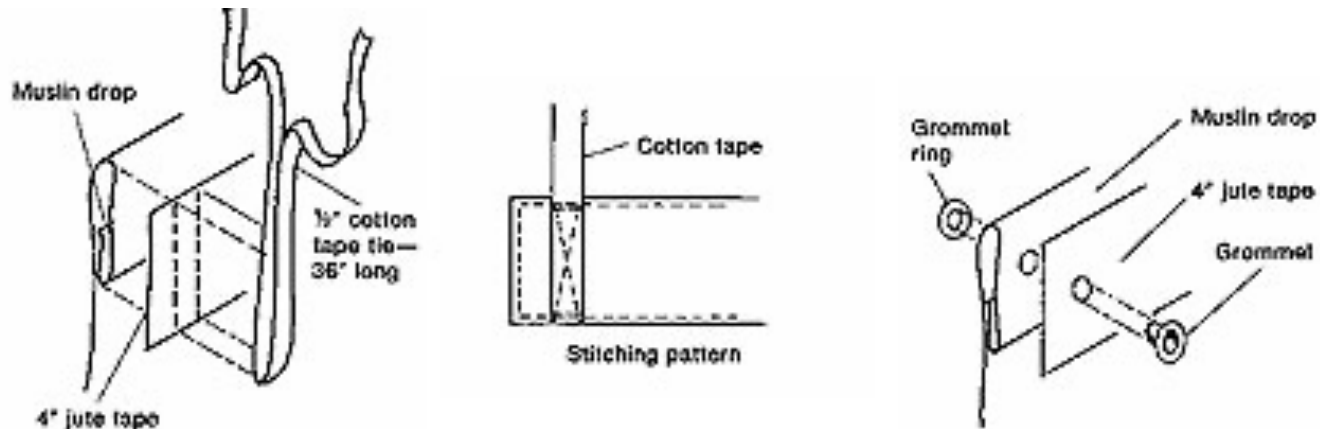

Soft Scenery: Batten-Clamp Drops

Drops are sometimes attached to a counterweight batten with batten clamps

The batten clamp facilitates rapid hanging or removal of a drop

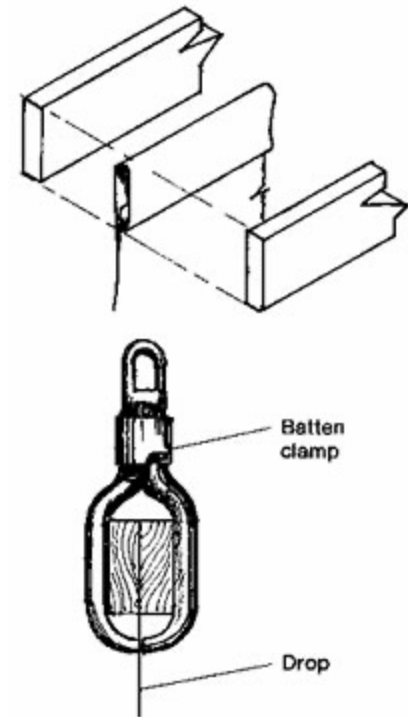

Soft Scenery: Opaque Drops

Made of heavyweight muslin, these drops are painted with opaque paints and are lit from the front

The audience cannot see through them

Soft Scenery: Translucent Drops

Made of heavyweight muslin, these types of drops are painted with dyes or a combination of dye and opaque paint

They are lit from both front and back, making the areas that have been dyed translucent

Soft Scenery: Scrim Drops

Made from sharktooth scrim or theatrical gauze, scrim drops can become transparent when the scene behind it is lit

They can be painted with either dyes or thinned paints

Soft Scenery: Cutout Drops

These types of drops have sections cut out of the material

They create a sense of depth and should be painted before being cut to prevent curling

Soft Scenery: Draperies

The two types of draperies used in the theatre are stage draperies and curtains

A more thorough discussion of stage draperies appears in Chapter 4, while curtains are covered in Chapter 11

Three-Dimensional Scenery

The term refers to the construction of platforms, stairs, and other similar objects

Rigid Wooden Platform

The easiest and least expensive stage platform to build

The legs are detachable, so its height can be easily varied

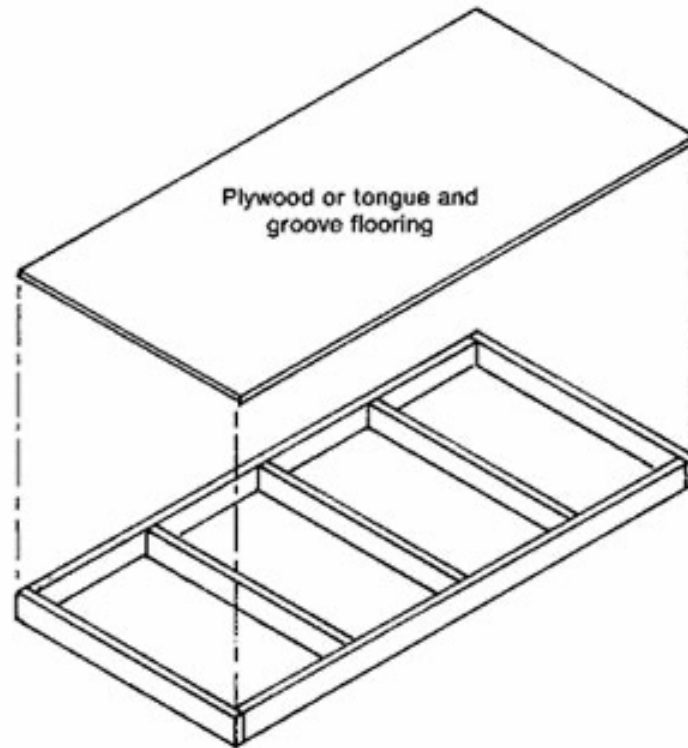

Rigid Teel-Tubing Platform

Steel tubing can also be used to fabricate rigid platforms

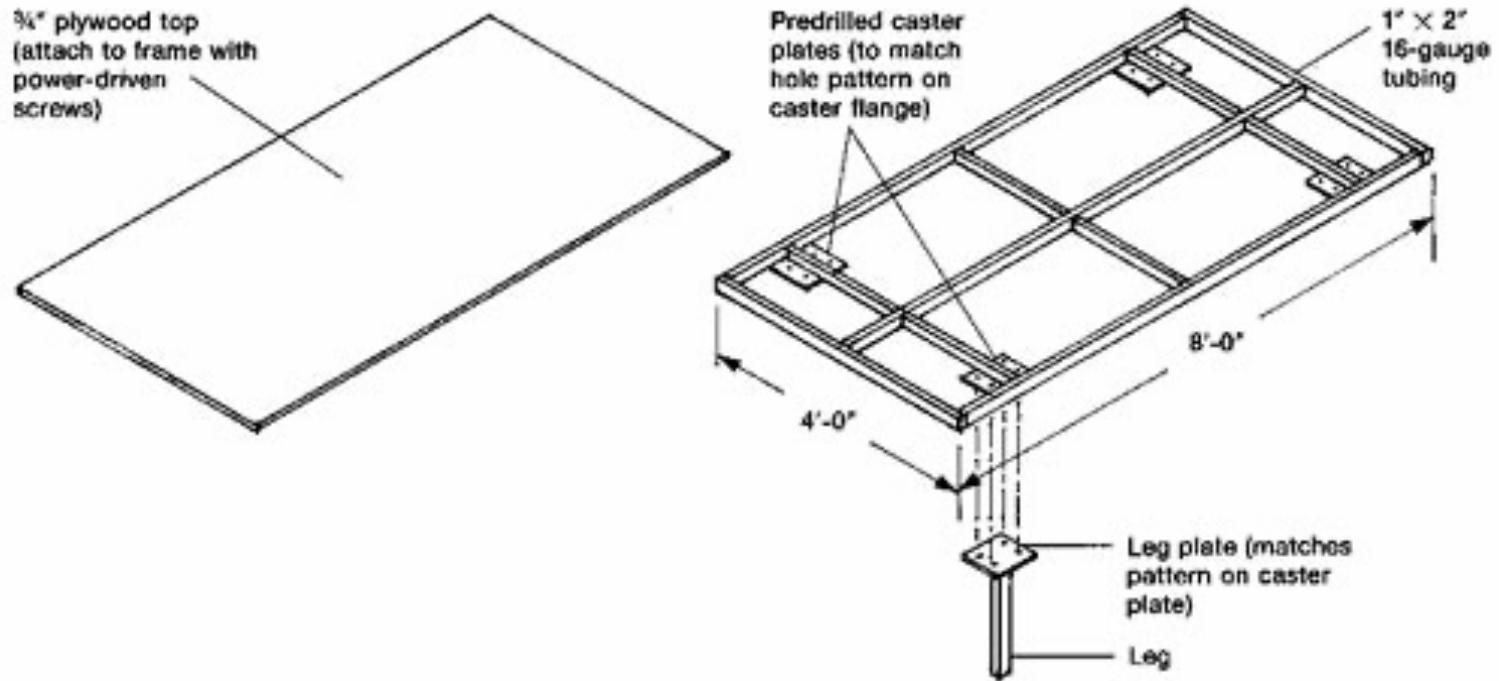

Rigid Platform Legs

Legs for rigid platforms can be fabricated from a variety of materials

All platform legs over 18 inches tall should be braced, regardless of the material of which they are made

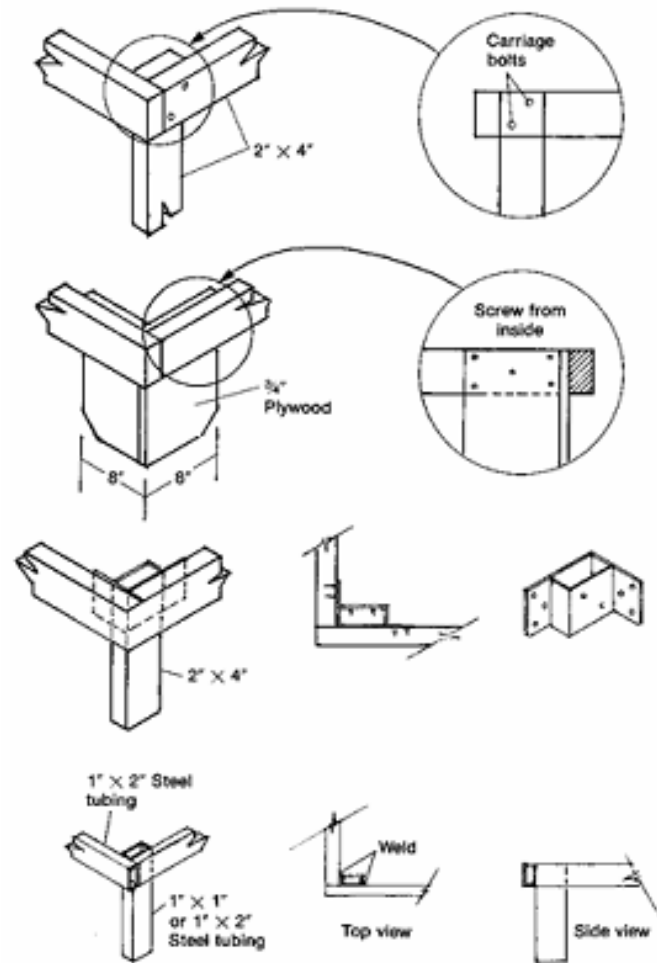

Stressed-Skin Platform

Stressed-skin construction involves securely gluing or screwing plywood “**skins**” to an internal framework that is nailed and glued

Because the skins can be “**laminated**” from two sheets of easily warped plywood, stressed-skin construction can be used for making curved platforms

Skin

A plywood covering for the top or bottom of a platform

Laminate: To build up an object from several layers

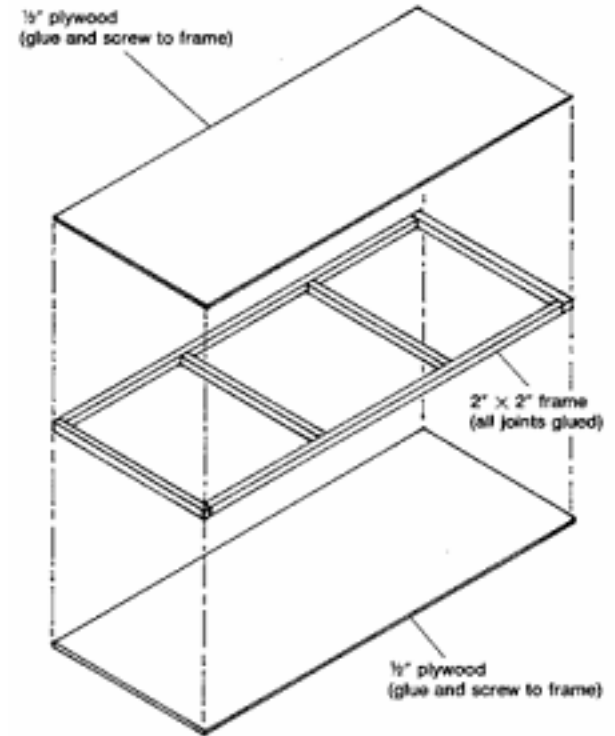

Honeycomb-Paper Lamination

This lamination method is based on the principles used to fabricate the wings of supersonic aircraft

These platforms are made by sandwiching “honeycomb paper” between two sheets of plywood

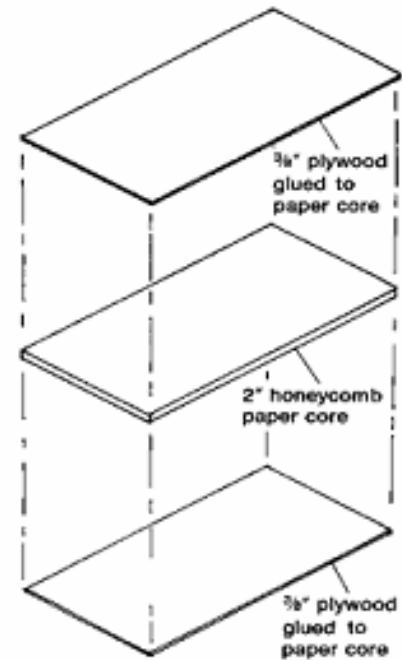

Enlarged view of honeycomb paper

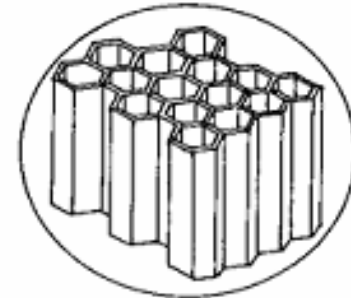

Honeycomb paper

A manufactured paper product with a hexagonal structure similar to a honeycomb

Parallels

Another type of platforming that comes in two varieties. In both, the top is removable and the framework folds for compact storage

Standard parallel: this platform is hinged to fold like a giant parallelogram

Continental parallel: this platform is hinged differently than the standard. It folds into a more compact unit, but its center supports must be removed first

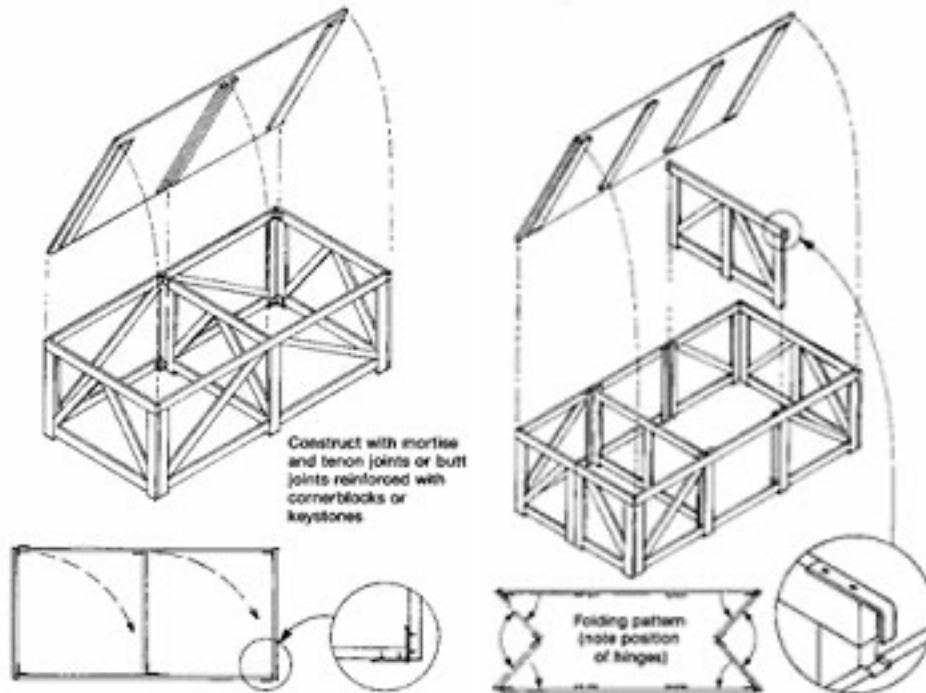

Connecting Platforms

Platforms must be connected to improve the lateral stability of the floor unit

Platforms can be connected in a number of ways

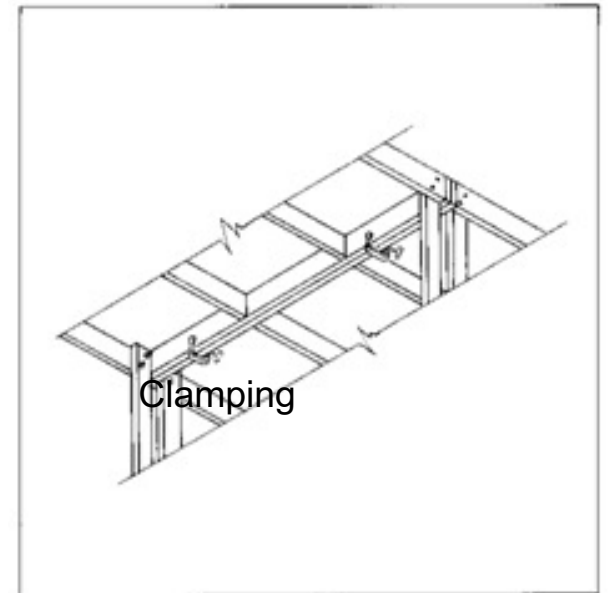
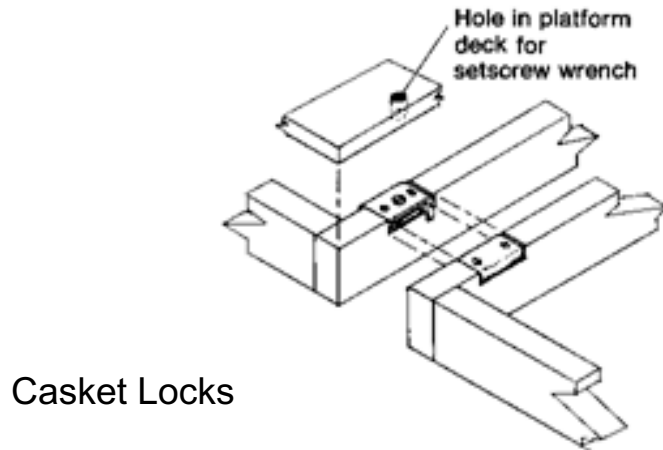
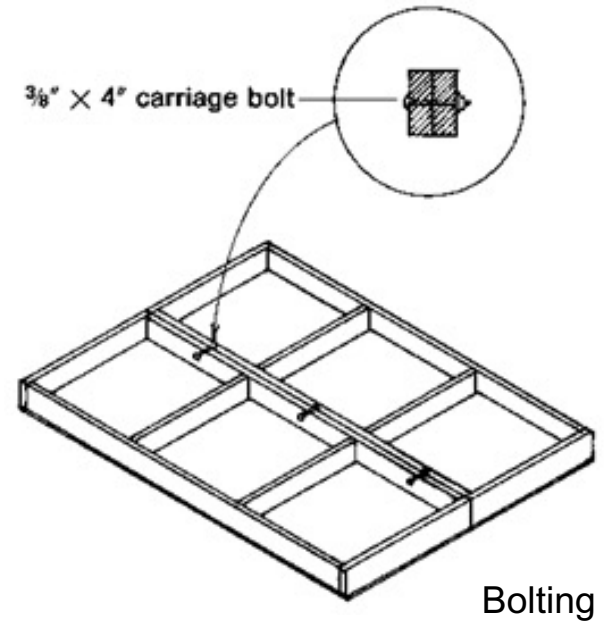

Stairs

Two basic types of stairs are used in scenic construction

Dependent—units that require support from some other element (such as a platform)

Independent—units that are self-supporting

While the support method is the primary difference between the two types of stairs, the actual construction of the units is similar

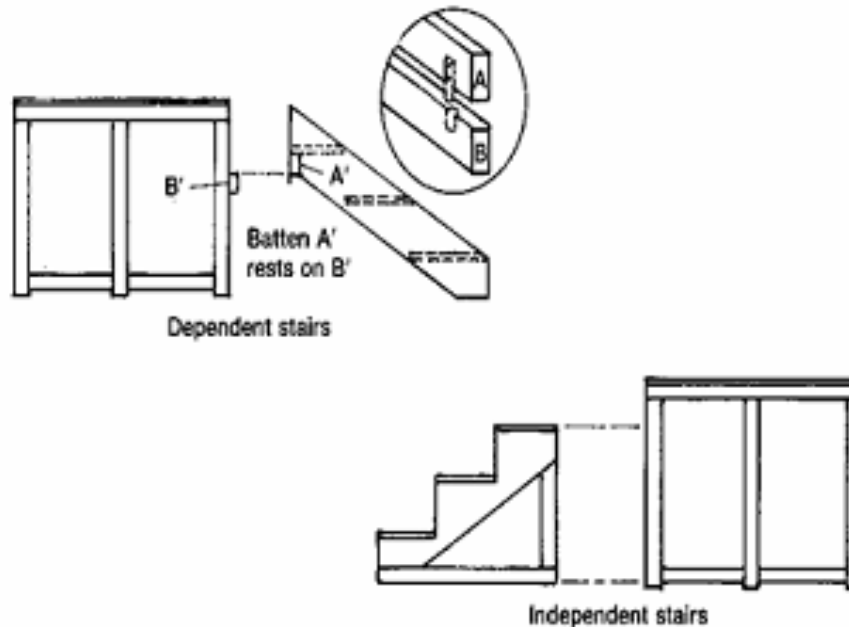

Wagons

Wagons are usually rigid platforms that rest on casters instead of legs

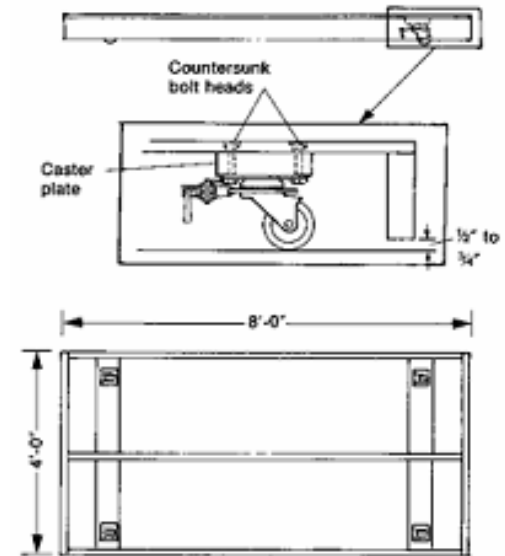
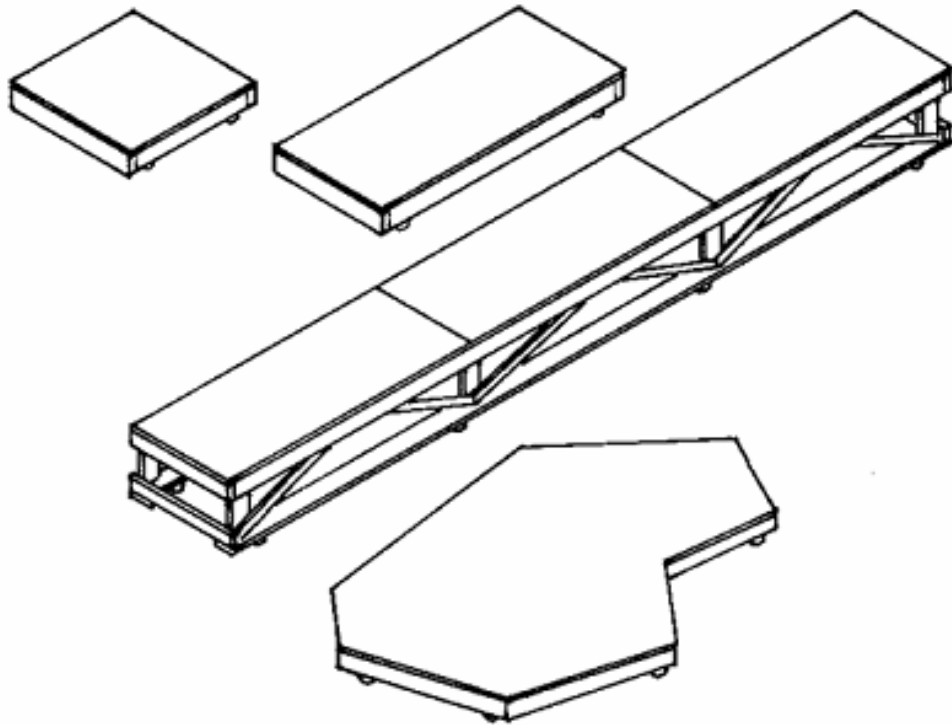

Trusses

Trusses are used when it is necessary to bridge a large span between supporting points

They can be wooden or welded-steel

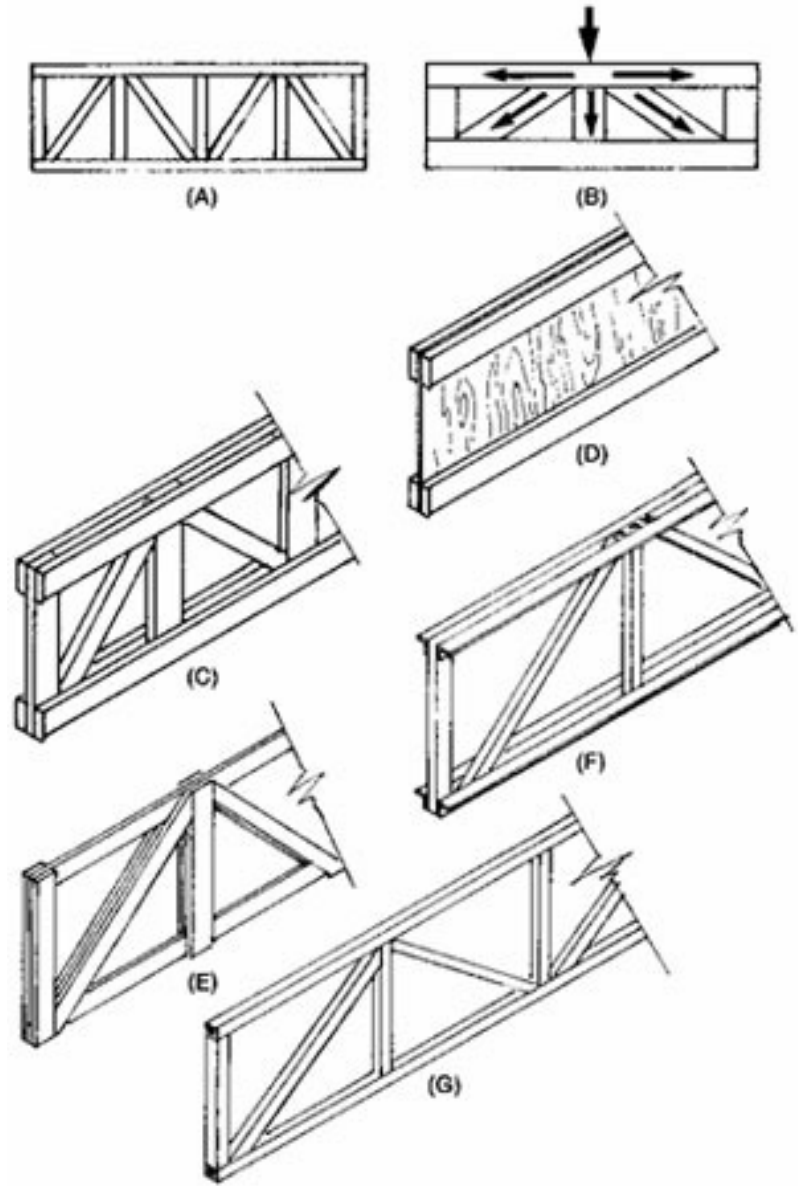

Revolves

Revolves are large, circular platforms that pivot on their central axis

Revolves can be built using any standard platform-construction technique

The rigid platform method seems to work best

Revolves
are also
called
turntables

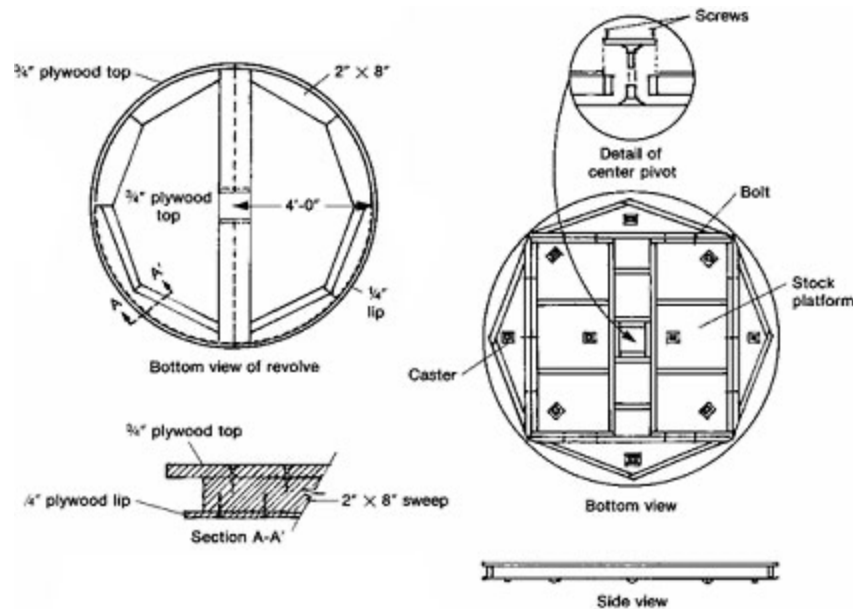

Winch-Drive Systems

(A) Hand cranked winch

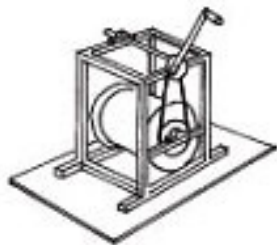

(B) Motorized winch

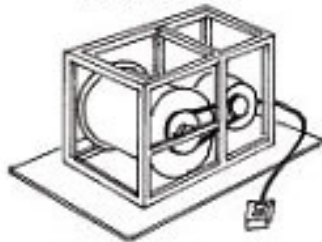

(C) Base plate detail

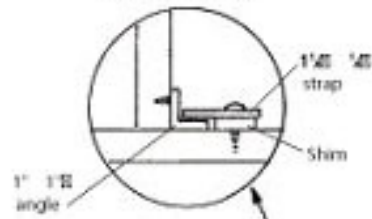

Base plate screwed to floor

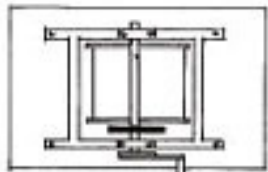

Top view

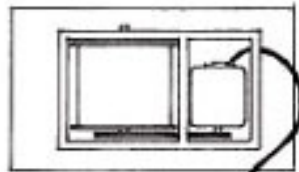

Top view

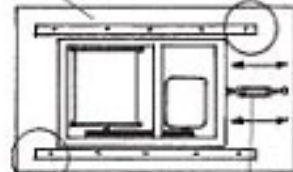

Top view

Cable drive can be adjusted by tightening or loosening the turnbuckle

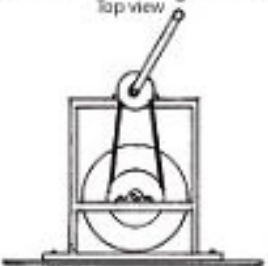

Side view

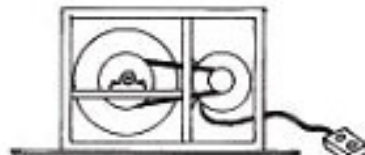

Side view

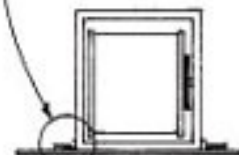

Front view

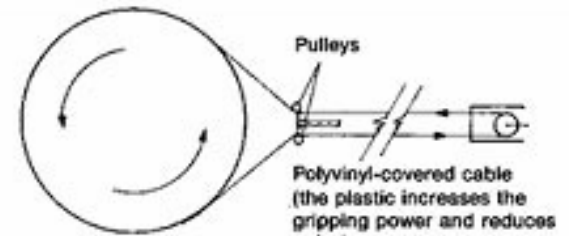

Top view

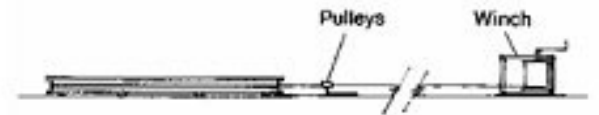

Side view

Note: Only wrap cable around drum once

Platform-Anchoring Techniques

Wagons that hold three-dimensional scenery need to be anchored

Lift Jack

Tip Jack

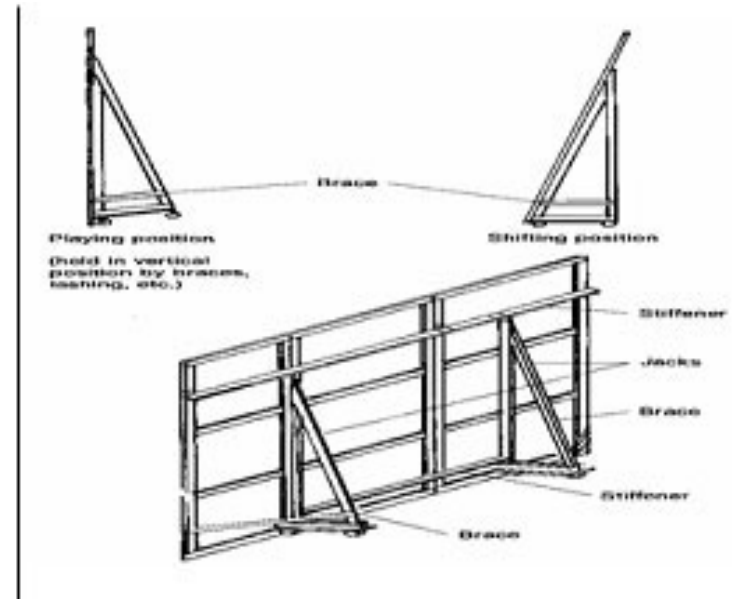
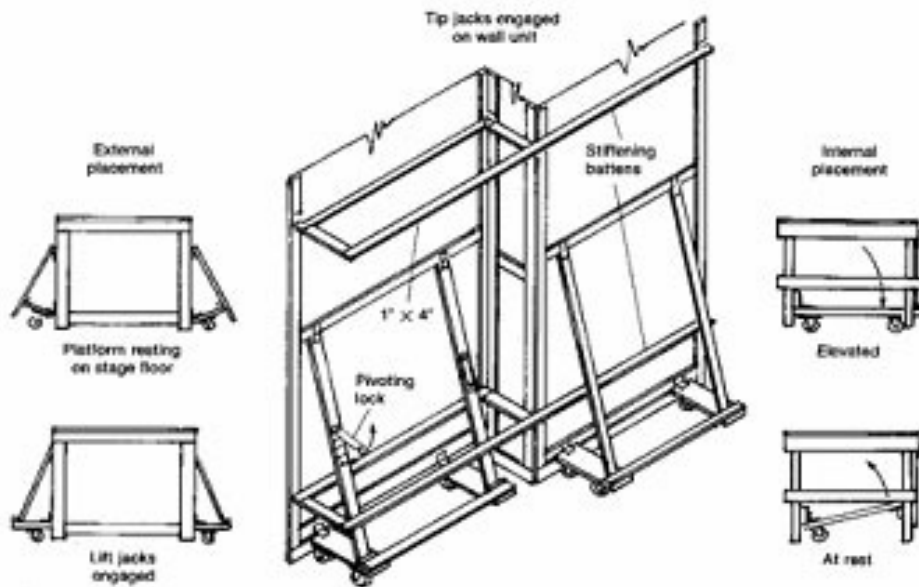

Rocks, Irregular Platforms, and 3-D Trees

All of these items are built in approximately the same manner

These items have surfaces that are not straight, square, or level

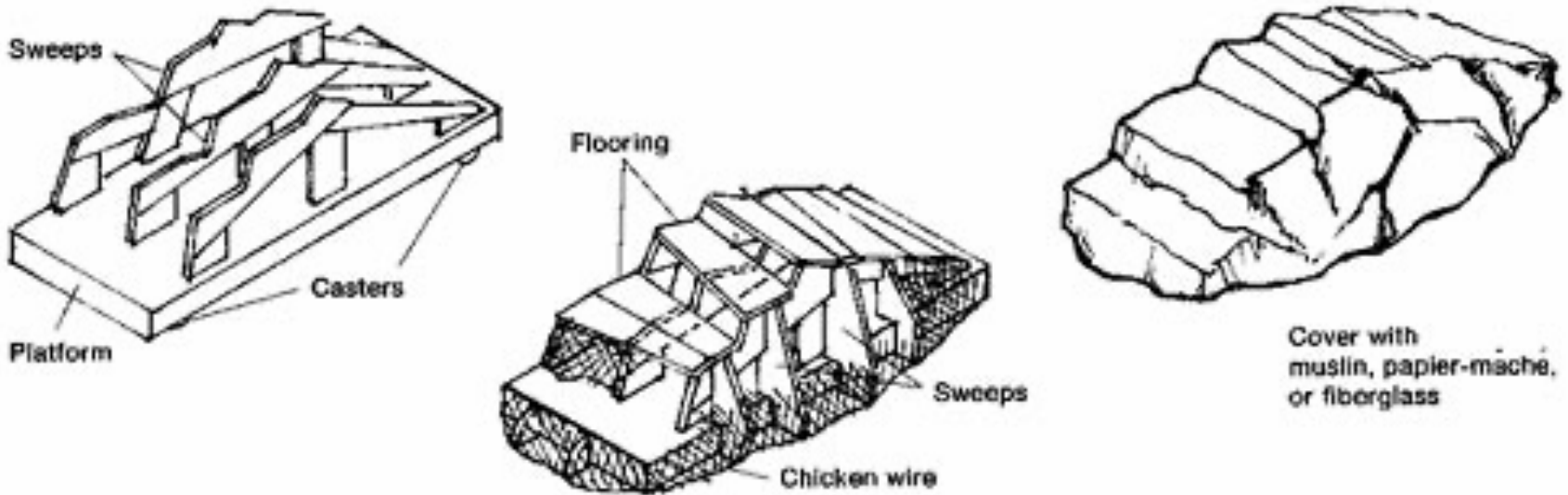

Rocks, Irregular Platforms, and 3-D Trees

The irregular quality is achieved with chicken wire and papier-mâché

Trees can also be constructed using burlap for the bark or foam

